

CHARM-Module



Embedded Video Tracker 50mm x 50mm (Compact Hardware – ARM)

The Vision4ce CHARM Module product uses the DART (Detection & Acquisition, with Robust Tracking) detection and target tracking software hosted on an embedded multicore ARM+GPU processor board for video tracking and image processing applications. It has all digital interfaces.

The CHARM Module is used as the core processing module on the Vision4ce standard form factor video trackers such as 3U VME/cPCI, 6U VME, PC-104, etc. Multiple modules can be integrated onto larger boards allowing for comprehensive multi-channel tracking solutions. It can also be directly integrated onto a host board for size, weight and power (SWAP) optimized systems.



Tracking a jet-ski using IR video



CHARM-Module

Key Features

- Multiple object detection and tracking
- Centroid & edge measurement
- Feature based correlation algorithm
- Moving object detection
- Adaptive background removal
- Automatic coast
- Grey level invariant algorithms
- Robust clutter rejection

Interfacing

- One parallel digital video input
- Video output through parallel and HDMI interfaces
- Host interface through serial or Ethernet interfaces
- Direct data interface to sensors or Pan & Tilt Platform through serial interface

Additional Image Processing options

- Electronic image stabilization
- Image enhancement
- Streaming of SD & HD video

Applications

- Security and surveillance
- UAV & UGV
- Manned vehicles
- Automated video analysis

Video Detection & Tracking

A video tracker analyses video image sequences from a sensor system (one or more cameras), mounted on a servo controlled pedestal (platform) to keep the camera pointing at the nominated person or object. In this context, a Tracker has two primary processing functions.

- Detecting and locating objects of interest in the video image (object location).
- Controlling the platform (Pan and Tilt) position and rate such that the camera follows the designated object (Pan and Tilt Control).

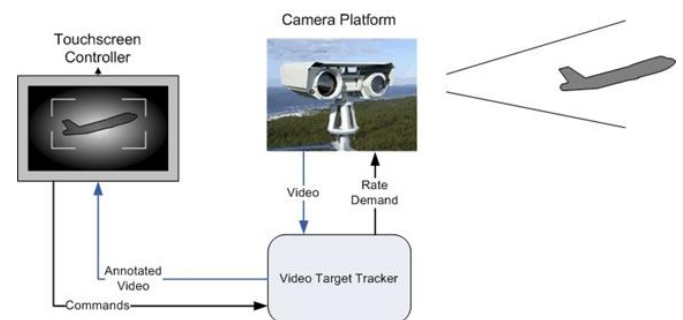

CHARM-Module

Interfaces

- Video Input (1)
 - ITU-R BT.656 or
 - ITU-R BT.1120 or
 - 8/16/24 bit parallel with separate syncs
- Video Output (2)
 - ITU-R BT.656 or ITU-R BT.1120
 - HDMI
- 2 x UARTs
- 1 x USB2.0
- GPIO
- 10/100/1000 Ethernet
- PCIe x1

Connectors

- 4x 70-way board to board plug

Power

- +5V, 3.3 VDC (5 watts)

Environmental

- Operating temperature -40C to +70C

Carrier Boards – Typical Options

The CHARM module can be integrated by the end customer to meet specific application and interface types. Vision4ce can also provide a baseline carrier board that is

populated with a generic range of interfaces for integration into customer systems for initial evaluation.

- CHARM 3U PCI/VME/VPX – 1 CHARM modules (CHARM 3U)
- CHARM 6U PCI/VME/VPX – 1 or 2 CHARM modules (CHARM 6U) CHARM -104 – On PC104 - 1 CHARM Module
- CHARM – XMC/PMC – 1 CHARM modules
- Custom – 1 to 4 modules

CHARM Carrier Boards – Design

A CHARM carrier board is a standalone video tracker board using the CHARM Module and specific interface components which then allows direct connection to standard video and data interfaces. Many potential features can be integrated – see below for examples

Typical Interfaces

- 4 x RS232/422/485
- 1 x USB2.0
- GPIO
- 10/100/1000 Ethernet
- NTSC/PAL/SECAM Composite video inputs and outputs
- RGB or YPbPr analogue HD video inputs and outputs
- HD-SDI, CoaXPress, HDMI or CameraLink digital HD video inputs
- Serial ATA 2.5 (SATA) @ 3 Gb/s

Designed and manufactured in the UK

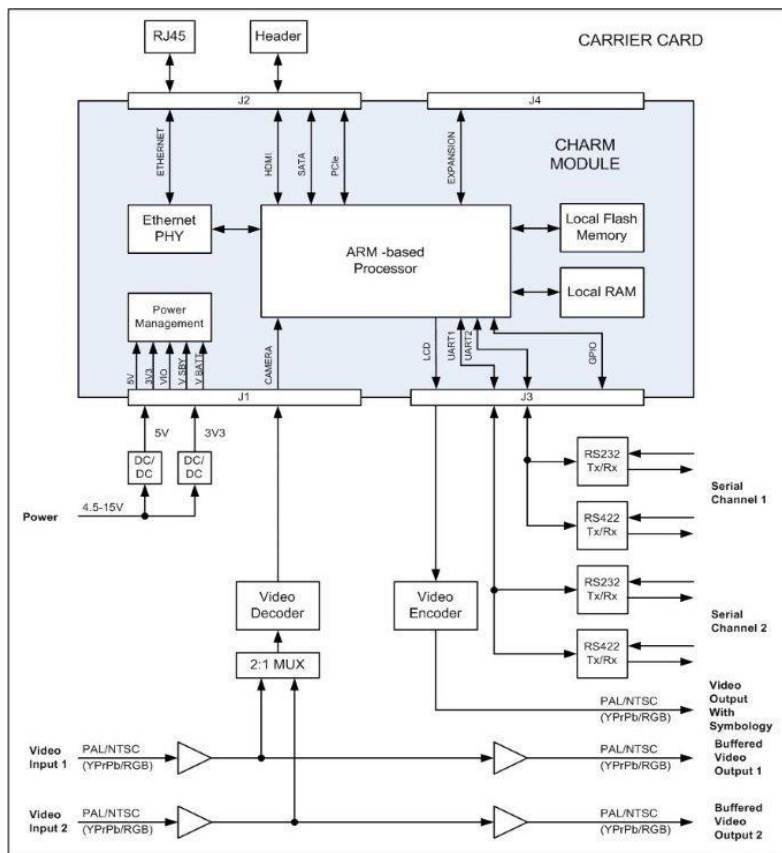

Example Carrier Card